

Hogmanay 2019

1 NEW YEAR JIG J32 · 3/4L

Maureen Robson: RSCDS LI 8 · Crib: MiniCribs · Diagram: Keith Rose's Diagrams

- 1-8** 1s dance Fig 8 on own sides (pass 2s RSh to start). 1L ends facing out
- 9-16** Reels of 3 on sides (1s+2s pass RSh to start). 1L end facing out
- 17-24** 1L followed by 1M dances behind 2L, up between 2s, behind 2M, across set to 2nd place own side (2s step up 23-24)
- 25-32** 1s+3s dance RH across. 2s+1s dance LH across. 1L finishes facing out, ready to start again

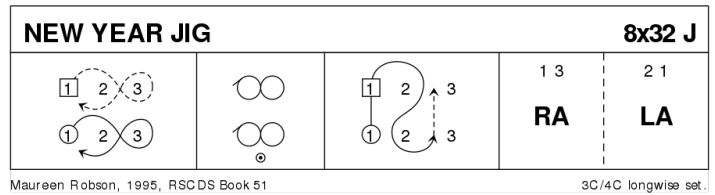

2 SCOTT MEIKLE R32 · 4/4L

Alice McLean: RSCDS XLVI 3 · Crib: MiniCribs · Diagram: Keith Rose's Diagrams

- 1-8** 1s cross RH & cast to 2nd place, 1s dance 1/2 Fig of 8 round 2s
- 9-16** 1s+3s dance RH across, LH back
- 17-24** 1L followed by 3L dance Tandem reel of 3 across with 2s (LSh to 2M) & 1s end 3rd pl **while** 3M followed by 1M dance reel of 3 with 4s (LSh to 4L) & 3s end in 2nd pl 2 3 1 4
- 25-32** 1s+4s dance 1/2 R&L, turn partners RH 1.1/2 times 2 3 4 1

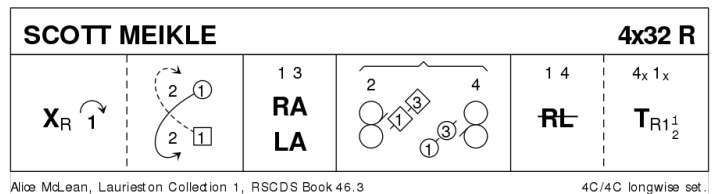

3 THE GOLDEN WEDDING STRATHSPEY S40 · 4/4L

Jimmy Ashton: RSCDS XXXIII 4 · Crib: MiniCribs · Diagram: Keith Rose's Diagrams

- 1-8** 1s followed by 2s+3s+4s cast to bottom on own sides, dance up & all curve out to original places
- 9-16** 1s+2s & 3s+4s Set+Link, 2s+1s & 4s+3s circle 4H round to left
- 17-24** 2s+1s & 4s+3s dance the Knot, 1s end BtoB between 2s on opposite sides
- 25-32** 1s dance the Spurtle: 1s dance 1/2 RSh reel of 4 with 2s & turn RH, 1s dance 1/2 reel of 4 with 3s & turn RH to face 4s
- 33-40** 1s dance 1/2 reel of across with 4s & turn RH to 4th place opposite sides, all set & cross RH

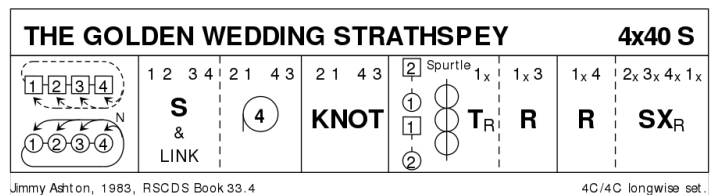

4 DUKE OF PERTH R32 · 3/4L

RSCDS I 8 · Crib: MiniCribs · Diagram: Keith Rose's Diagrams

- 1-8 1s turn RH, cast to 2nd place, turn LH to face 1st corners
- 9-16 1s turn 1st corner, partner, 2nd corner, & partner to face 1st corners
- 17-24 1s set to & turn 1st corner 2H, set to & turn 2nd corner
- 25-32 1s dance Reel of 3 on opposite sides giving LSh to 1st corner & cross back to own sides

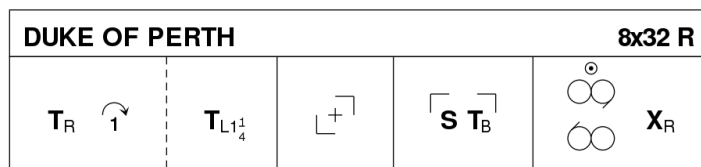

The Ballroom, 1827, RSCDS Book 1.8

3C/4C longwise set.

5 SWASHBUCKLING IAIN J32 · 2/4L

Carolyn Hunt: San Francisco Collection Volume 2 · Crib: MiniCribs · Diagram: Keith Rose's Diagrams

- 1-8 1M dances reel of 3 on opposite side with 1L+2L (RSh to 2L)
- 9-16 1M followed by partner dances Tandem reel of 3 across with 2s (RSh to 2M)
- 17-24 1M followed by partner dances down the middle & leads her up to top
- 25-32 1s+2s dance Allemande

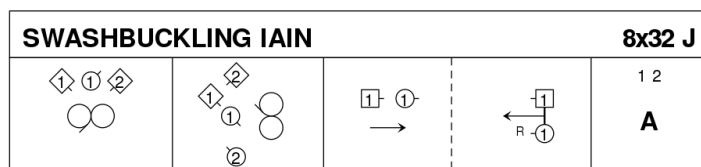

Carolyn Hunt, 1991, San Francisco II

2C/4C longwise set.

6 "DEER" FRIENDS S32 · 3/4L

Bob Anderson: The Saint Martin Coll. of New Scottish Country Dances vol. 1 · Crib: MiniCribs · Diagram: Keith Rose's Diagrams

- 1-8 1s cross down RH, cast behind 3s, cross RH, cast up 1 place, turn 3/4 LH to join RH with 3rd corners in a diagonal line
- 9-12 Balance in Line figure:
 9 All set 1 step Right, change hands so that 1s and 3rd corners take LH
 10 1s and 3rd corners 1/2 turn LH, retain LH and 1s join RH in middle of line
 11 All set 1 step R, 1s join LH & drop hands with corners
 12 1s 1/2 turn LH to face 3rd corners **while** corners set 1 step Left turning to face diagonally in
- 13-16 1s dance 1/2 diagonal reel of 4 with 3rd corners, finish facing 4th corners
- 17-24 Repeat bars 9-16 with 4th corners, 1s crossing LH to finish in 2nd place opp sides End (3)(1)(2)
- 25-32 Set and link for 3 couples twice to finish 213 on own sides

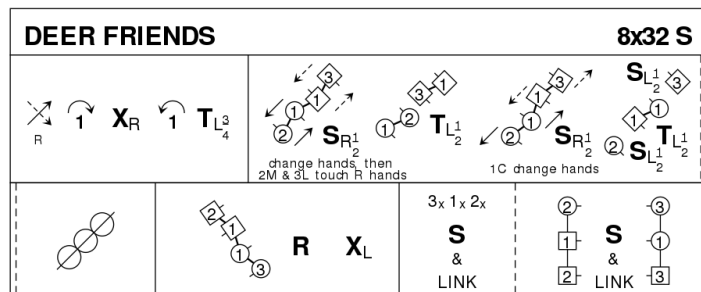

Bob Anderson, 2000, Saint Martin Collection of New SCDs

3C/4C longwise set.

7 THE CASTLE OF MEY R32 · 3/4L

John Walton: QE Diamond Jubilee Dances · Crib: MiniCribS · Diagram: Keith Rose's Diagrams

- 1-8** 1s dance Inveran reels with 2s+3s
9-16 1s+2s dance double Figs of 8 (1s start by crossing down)
17-24 1s lead down the middle & up, 1s end in middle of the set
25-32 1s+2s dance Poussette

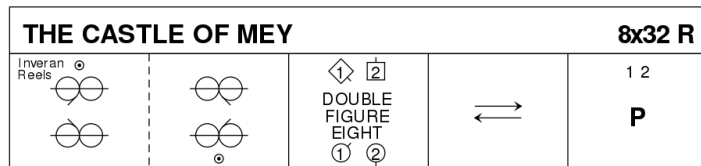

John Walton, 2012, RSCDS QE Diamond Jubilee

3C/4C longwise set..

8 FAREWELL TO BALFOUR ROAD J32 · 5/5L

Andrew Buxton: RSCDS LII 7 · Crib: MiniCribS · Diagram: Keith Rose's Diagrams

- 1-8** 1s+2s circle 4H round & back
9-16 1s+2s Set+Link; 1s+3s Set+Link
17-24 2s *start while* 1s+4s+5s dance mirror reels of 3 on sides (1s in/down to start)
25-32 1s set, cross down RH to 4th place (4s step up); 1s set, cross down LH to 5th place (5s step up) 2 3 4 5 1

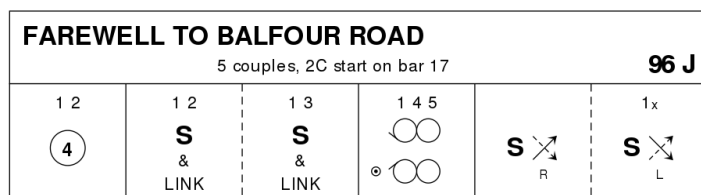

Andrew Buxton, 2015, RSCDS Book 52.7

5C/5C longwise set..

New top couple start every 16 bars. Repeat until 1s back in 1st place, they stand for 16 bars while 5s continue bars 17-32 ending back in 5th place

9 RAMADAN-CE R32 · 3/4L

John Drewry: The Turkish Set · Crib: MiniCribS · Diagram: Keith Rose's Diagrams

- 1-8** 1s dance Inveran Reels with 2s+3s
9-16 1s cross RH, cast 1 place & turn RH to face 1st corners
17-24 1s dance RSh round 1st corner, pass RSh & dance RSh round 2nd corner to end 2nd place opposite side **while** 1st corners dance in, 1/2 turn RH, twirl & dance out to each others place, 2nd corners dance similarly. (3)(1)(2)
25-32 1s dance 1/2 LSh reels of 3 across (Man at top with 3s & Lady at bottom with 2s), 1s dance 1/2 RSh reels of 3 on own sides (Man Down, Lady up)

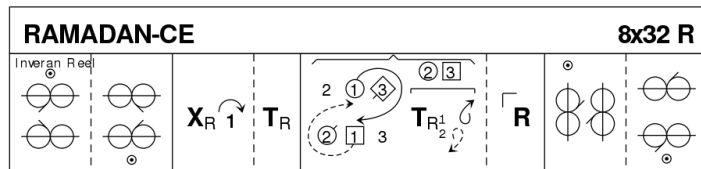

John Drewry, 2000, Turkish Set

3C/4C longwise set..

10 THE SINGING SANDS S32 · 3/3L

Barry Priddey: *The Silver Rose Book of Scottish Country Dances* · Crib: *MiniCribs* · Diagram: *Keith Rose's Diagrams*

- 1-8** 1s & 2s dance the Tourbillon :
1s & 2s turn partners 2H 1/2 way, 1M & 2L lead partners on 1 place clockwise to end 1s on Ladies side & 2s on Men's side, 1s set to 2s
1s & 2s 1/2 turn partners 2H, 1L & 2M lead partners on 1 place to end 2s in 1st pl & 1s in 2nd pl & 2s+1s cross RH to own sides
- 9-16** 1s dance 1/2 Figs of 8 (Man round 2s & Lady round 3s), 1s dance 1/2 reels of 3 (Man with 3s & Lady with 2s)
- 17-24** 1s dance Diag R&L to end 3 1 2
- 25-32** All set & 3s+1s dance RH across 1/2 way **while** 2s cross RH, all chase clockwise 1/2 way to end 2 3 1

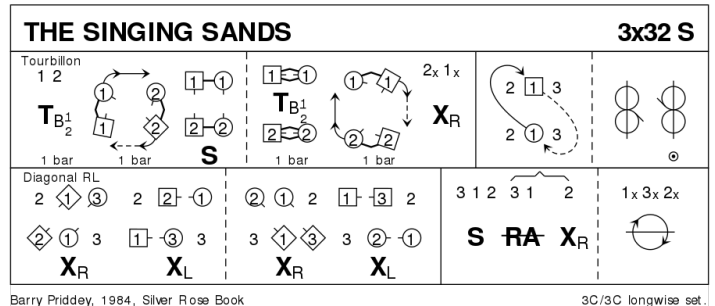

11 CHASED LOVERS J32 · 3/4L

Tim Wilson: *World Wide Weavings* · Crib: *MiniCribs* · Diagram: *Keith Rose's Diagrams*

- 1-4** 1s set, cross down (no hands) to 2nd place facing out (2s step up 3-4)
- 5-8** 1s cast down behind 3s, meet & dance up centre with 1L leading, 1M following, to face 2M (her 1st corner)
- 9-16** 1s, in tandem, dance LSh reel of 3 on 1st corner diagonal (out of top of set to start), finishing by 1s pulling back RSh to face down, 1M leading, facing 3M
- 17-24** 1s, in tandem, dance RSh reel of 3 on 2nd corner diagonal (out bottom of set to start), finishing with 1s facing own 1st corners
- 25-32** 1s dance Pass+Turn with 1st corners, (pass RSh), Pass+Turn with 2nd corners, finishing passing RSh to 2nd place own sides

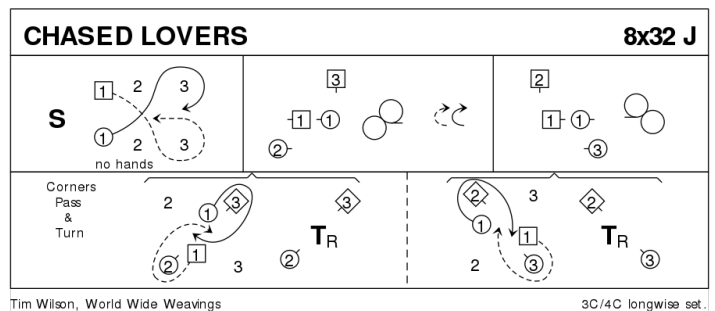

12 MAXWELL'S RANT R32 · 3/4L

David Rutherford: *RSCDS XVIII 10* · Crib: *MiniCribs* · Diagram: *Keith Rose's Diagrams*

- 1-8** 1s cross down to dance reflection reels of 3 on opposite sides
- 9-16** 1s cross down to dance reflection reels of 3 on own sides
- 17-24** 1s cross RH, cast to 2nd place & dance 1/2 Fig of 8 round 2s
- 25-32** 1s dance down between the 3s, cast up to 2nd place & 2s+1s+3s turn partners RH

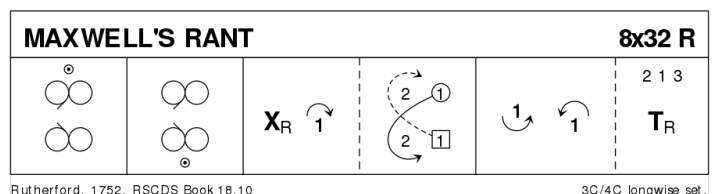

13 INTERVAL

14 PELORUS JACK J32 · 3/4L

Barry Skelton: RSCDS XLI 1 · Crib: MiniCrib · Diagram: Keith Rose's Diagrams

- 1-8** 1s cross RH & cast 1 place, dance RH across with 3s. 1s end with Man facing his 1st corner with his partner behind him
- 9-16** 1s dance Alternating Tandem 1/2 reel of 3 with 1st corners to face Man's 2nd corner, 1s dance Alternating Tandem 1/2 reel of 3 with 2nd corners
- 17-24** 1s dance Alternating Tandem 1/2 reels of 3 with Ladies' 1st corner (pstrn), 1s dance Alternating Tandem 1/2 reel with Ladies' 2nd corner (pstrn)
- 25-32** 1M followed by partner dance into LH across with 2s, 1s retain LH & 1/2 turn to own sides & 2s+1s+3s set

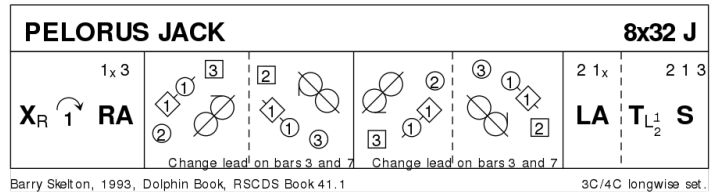

15 THE ORCHARDS OF CO. ARMAGH S32 · 3/3L

Jinty Anderson: Belfast Branch Platinum Anniversary Dances · Crib: MiniCrib · Diagram: Keith Rose's Diagrams

- 1-8** 1M leading 2M+3M also 3L leading 2L+1L chase clockwise 1/2 round to opp sides (4 bars). All set, 1s+3s turn partners 3/4 RH into line up/down (Men facing down)
- 9-12** 3s+1s dance 1/2 reel of 4, 1M+3L pass LSH to face 2s (1M+2M & 3L+2L facing), 1L+3M remain in centre at top/bottom
- 13-16** 1M+3L+2s dance 1/2 reel of 4 across, 1M & 3L pass LSh to face partners up/down set
- 17-24** 1s+3s dance 1/2 reel of 4, 1M+3L pass LSh to face own partners. 3s+1s set, petronella turn to own sides. 3 2 1
- 25-32** 2s followed by 1s dance up to top, cast, 2s to 3rd place, 1s to 2nd place (4 bars). 3s+1s+2s turn partners 2H

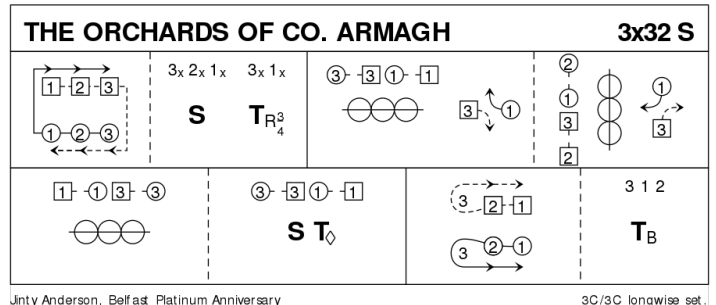

16 STAIRCASE IN STYRIA R40 · 5/5L

Margaret Gray: CD booklet of The Sunday Class Dance Book 2 · Crib: MiniCrib · Diagram: Keith Rose's Diagrams

- 1-8** 1s+2M also 3s+4M dance RH across, 1s+2L also 3s+4L dance LH across
- 9-16** 1s+4M also 3s+5M dance RH across, 1s+4L also 3s+5L dance LH across & 1L also 3L end facing out Ladies side with partners behind them
- 17-24** 1s & 3s dance out Ladies' side & cast up 1 place, cross to Mens side & cast up to original place Ladies looping round by the right
- 25-32** 1s cross & cast 1 place, 1s followed by 3s dance up & cast (1s to 3rd place, 3s to 2nd place)
- 33-40** 1s cross & cast 1 place, 1s followed by 5s dance up & cast (1s to 5th place, 5s to 4th place). 2 3 4 5 1
NB - No stepping up or down until bar 27

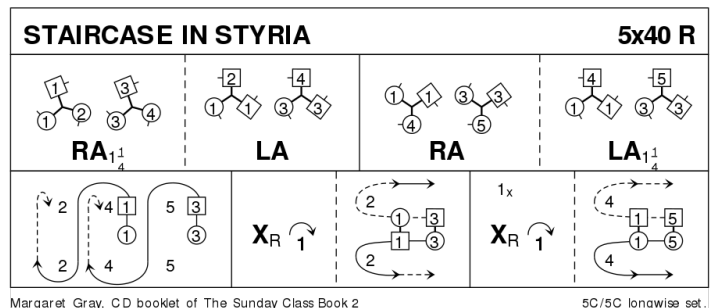

17 THE ELEPHANT'S STAMPEDE

J48 · 4S

Lorna Macdonald & Gillian Mackintosh: Aurora 10th Anniversary Book of SCD · Crib: MiniCribbs · Diagram: Keith Rose's Diagrams

- 1-8 All circle 8H round & back
 9-16 1s+3s advance & with free hand join with 2s & 4s & retire into longwise set across the dance, all dance 1/2 parallel reels of 4 across
 17-24 All dance 1/2 R&L at each end of set, turn (person on Mans left) RH 1.1/2 times to form Sq.Set
 25-32 All Ladies petronella turn to next Ladies place to right & set, repeat to meet partner (all have progressed 1 place to right)
 33-48 All dance full Schiehallion Reel

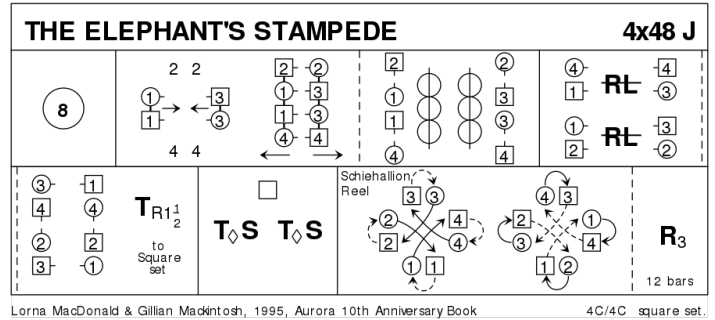

18 CHASING THE ECLIPSE

S32 · 3/3L

Sandy Gallimore: The Highland Road Collection · Crib: MiniCribbs · Diagram: Keith Rose's Diagrams

- 1-8 1s set, dance down below 3s (2s step up), cast up to 2nd place, pass LSh to face 1st corners
 9-16 1s dance RSh reels of 3 on opposite sides, 1s end facing 1st corners
 17-24 1s set to 1st corners, dance 3/4 round partner by RSh, 1s set to 2nd corners, dance round partner to own side, face out,
 25-32 Promenade (Chaperoned) Chain progression:
 25-26 2s & 3s 3/4 turn partner RH into middle **while** 1s dance clockwise 1/4 round the set picking up 2L/3M ...
 27-30 who promenade 1/2 way clockwise **while** middle people (2M + 3L) turn LH 1.1/2.
 31-32 2s & 3s turn partner RH 3/4 to own sides **while** 1s dance clockwise 1/4 round to end in 2nd place. 3 1 2



19 THE HIGHLAND RAMBLER

R40 · 3/4L

Roy Goldring: Silver Jubilee 25 - Leeds Branch · Crib: MiniCribbs · Diagram: Keith Rose's Diagrams

- 1-8 1s dance in & cast to 2nd place, dance RH across with 3s
 9-16 2s+1s dance LH across, 1L followed by partner cast up round 2L & dance down middle to 1L between 3s & 1M between 2s
 17-24 1s+2s+3s dance down the middle & back
 25-32 1M followed by partner cast down round 2L to 2nd places on own side & turn RH
 33-40 2s+1s+3s circle 6H round & back

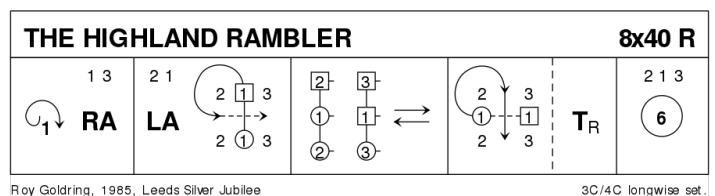

20 THE ELUSIVE MUSE J32 · 3/3L

Tim Wilson: Measures of Pleasure · Crib: MiniCribs · Diagram: Keith Rose's Diagrams

- 1-8** 1L dances RSh round prtnr to face 2L, 1s (1L leads) dance 1/2 Tandem reel of 3 across with 2s (LSh to 2L) ending 2s to top & 1s facing down
- 9-16** 1s dance down (4 bars), Lady turns under Mans arm & dance up to face 3L
- 17-24** 1s (1L leads) dance 1/2 Tandem reel of 3 across with 3s (RSh to 3L), 1s dance up to top & cast to 2nd place opposite sides
- 25-32** 2s+1s+3s Set+Link for 3 twice to end 3 1 2

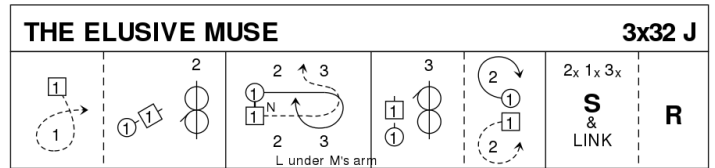

21 NEIDPATH TOWER S32 · 4/4L

Rod Downey: They Stole my Wife From Me Last Night · Crib: E-cribs · Diagram: Keith Rose's Diagrams

- 1-** All set | all turn BH twice | all set
- 9-** G-Chain (1c and 4c cross to start)
- 17-** 1c+4c Fig8 on own side round 2c+3c, starting inwards, 1c passes in front of 4c each time. On [24] 2c+3c dance in for
- 25-** 1c+2c & 3c+4c ½ Poussette, on [28] 2c+3c dance to sidelines as 1c+4c continue slow turn ; 1c+4c ½ Poussette (2,4,1,3)

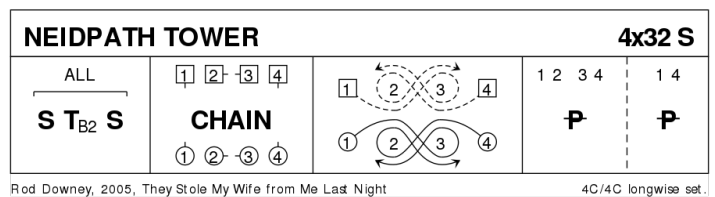

This 4c variation of »Neidpath Castle« was devised whilst sitting out during Neidpath Castle.

22 SWISS LASSIE R32 · 3/4L

Rosi Betsche: RSCDS XXXIX 1 · Crib: MiniCribs · Diagram: Keith Rose's Diagrams

- 1-8** 1s dance in & cast to 3rd place, 2s+1s turn partners RH 1.1/4 times to form a line up & down middle of set (Men facing down Ladies up)
- 9-16** 2s+1s dance reel of 4 up & down middle of set ending with 2M facing Ladies side & 1L facing Men's side
- 17-24** 2s+1s chase round clockwise 1/2 way, 1s+3s+2s Adv+Ret
- 25-32** 3s+2s (bottom 2 couples) 1/2 turn partners RH, dance RH across 1/2 way, 1s+2s (top 2 couples) 1/2 turn partners RH & dance RH across 1/2 way

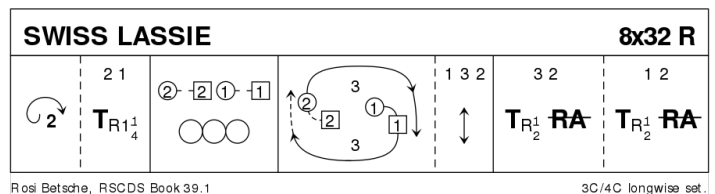

23 ST BERNARD'S WALTZ W16 · 1RR

Bill Smith: Collins Pocket Reference: Scottish Country Dancing · Crib: MiniCribs · Diagram: Keith Rose's Diagrams

Couples in ballroom hold face anticlockwise round room, Ladies on the outside

- 1-8** All in waltz hold take 3 steps (Lady right, Man Left) & stamp both feet, 2 steps in opposite direction then 2 steps towards centre (start Lady right foot, Man left foot)
- 9-16** All take 2 steps back out & Lady turns under Man's right arm, all waltz round room

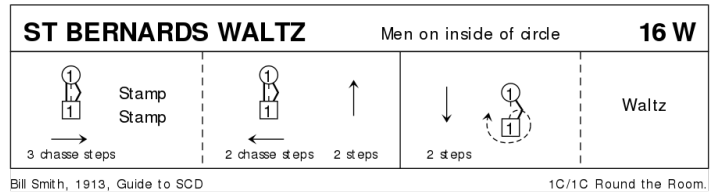

24 WEST'S HORNPIPE R32 · 4/4L

Five Traditional Scottish Country Dances for 1965 · Crib: MiniCribs · Diagram: Keith Rose's Diagrams

- 1-8** 1s cross down & dance reflection reels of 3 on opposite sides
- 9-16** 1s cross down to dance reflection reels of 3 on own sides
- 17-24** 1s lead down the middle & back to top (1s end facing 2s diagonally)
- 25-32** 1s set to 2s & dance down to 4th place (2s+3s+4s step up 27-28), 4s+1s circle 4H round to left

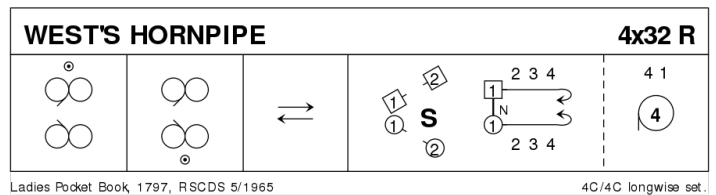

25 MAIRI'S WEDDING R40 · 3/4L

James B Cosh: Twenty Two SCD · Crib: MiniCribs · Diagram: Keith Rose's Diagrams

- 1-8** 1s turn RH & cast to 2nd place, 1s turn LH to face 1st corners
- 9-16** 1s dance 1/2 diagonal reel of 4 with 1st corners, 1s dance 1/2 diagonal reel with 2nd corners
- 17-24** 1s dance 1/2 diagonal reel with 3rd corner (pstns), 1/2 diagonal reel with 4th corner (pstns)
- 25-32** 1s dance reel of 3 across (Lady with 2s, Man with 3s - LSh to 1st corner)
- 33-40** 2s+1s+3s circle 6H round & back

