

# Hogmanay 2021

## 1 THE FINDLAYS' JIG J32 · 3/4L

Roy Goldring: 14 Social Dances for 2000 · Crib: MiniCrib · Diagram: Keith Rose's Diagrams

- 1-8 1s lead down the middle & back
- 9-16 1s+2s+3s dance Allemande
- 17-24 1s dance in & cast up to top, 2s dance in & cast up to top
- 25-32 2s+1s+3s circle 6H round & back

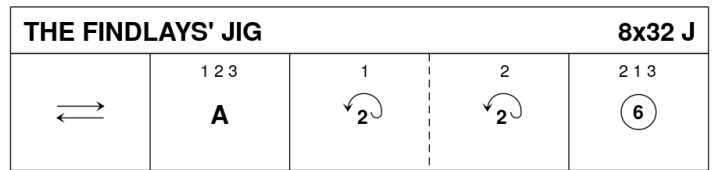

R Goldring, 2000, 14 Social Dances for 2000

3C/4C longwise set.

## 2 SCOTT MEIKLE R32 · 4/4L

Alice McLean: RSCDS XLVI 3 · Crib: MiniCrib · Diagram: Keith Rose's Diagrams

- 1-8 1s cross RH & cast to 2nd place, 1s dance 1/2 Fig of 8 round 2s
- 9-16 1s+3s dance RH across, LH back
- 17-24 1L followed by 3L dance Tandem reel of 3 across with 2s (LSh to 2M) & 1s end 3rd pl **while** 3M followed by 1M dance reel of 3 with 4s (LSh to 4L) & 3s end in 2nd pl 2 3 1 4
- 25-32 1s+4s dance 1/2 R&L, turn partners RH 1.1/2 times 2 3 4 1

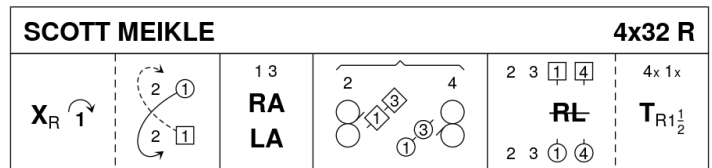

Alice McLean, Laurieston Collection 1, RSCDS Book 46.3

4C/4C longwise set.

## 3 MIDSUMMER COMMON S32 · 3/4L

Tom & Lindsey Ibbotson: RSCDS XLIX 3 · Crib: MiniCrib · Diagram: Keith Rose's Diagrams

- 1-8 1s set, 1/2 turn RH, lead down, cross below 3s, cast up to 2nd place own sides (2s step up 5-6)
- 9-16 1s set advancing to 1st corners & turn 1st corners 2H finishing 1M between 3s, 1L between 2s. 1s set advancing to 2nd corners, turn 2nd corners 2H & retain 2nd corner's LH
- 17-24 1M+2s also 1L+3s circle 3H round to Left, 1s pull back RSh to face up/down set. 1s set, petronella turn to 2nd place own sides
- 25-32 2s+1s dance Poussette. 2 1 3

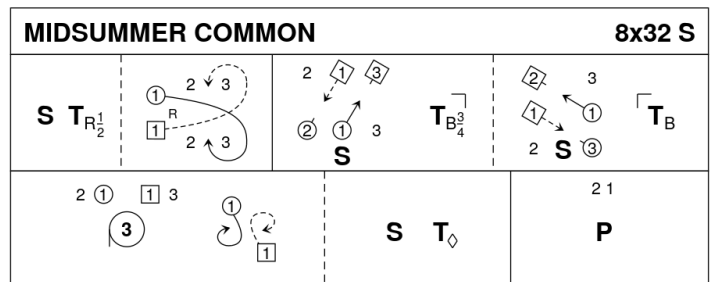

Tom and Lindsey Ibbotson, 2013, RSCDS Book 49.3

3C/4C longwise set.

## 4 DUKE OF PERTH R32 · 3/4L

RSCDS I 8 · Crib: MiniCrib · Diagram: Keith Rose's Diagrams

- 1-8 1s turn RH, cast to 2nd place, turn LH to face 1st corners
- 9-16 1s turn 1st corner, partner, 2nd corner, & partner to face 1st corners
- 17-24 1s set to & turn 1st corner 2H, set to & turn 2nd corner
- 25-32 1s dance Reel of 3 on opposite sides giving LSh to 1st corner & cross back to own sides

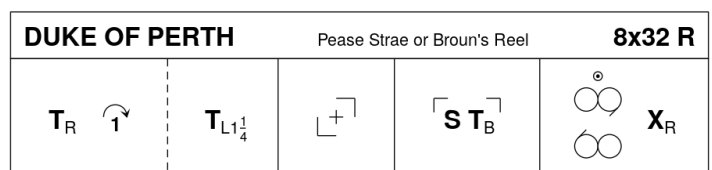

Boulogne, 1827, RSCDS Book 1.8

3C/4C longwise set.

## 5 ECCLEFECHAN FELINE J32 · 3/4L

Bob McMurtry: Le Petit Chat Celtique · Crib: MiniCrib · Diagram: Keith Rose's Diagrams

- 1-8 1s dance Fig. 8 on own sides (1s dance in/down to start), taking nearer hands where possible
- 9-16 1s+2s+3s mirror (reflection) reels on own sides (1s in/down, 2s out/up, 3s in/up to start)
- 17-24 1s lead down (3 bars), lead back up (3 bars) cast into 2nd place own sides
- 25-32 1M with 3s, 1L with 2s, dance RH across, 1s pass RSh to dance LH across other end (1M with 2s, 1L with 3s)

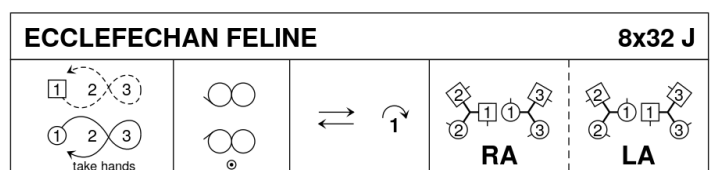

Bob McMurtry, Le Petit Chat Celtique

3C/4C longwise set.

**6 CITY OF BELFAST S32 · 3/3L**

Lucy Mulholland: RSCDS XLVIII 6 · Crib: MiniCribs · Diagram: Keith Rose's Diagrams

- 1-8** 1s dance 1/2 Fig of 8 round 2s, 1L+2M turn RH 1.1/4 times **while** 1M+2L turn LH 1.1/4 times & 1s end BtoB facing opp sides
- 9-16** 1s+2s dance reel of 4 across in 2nd place. 2s end in 1st places **while** 1s pass LSh to face 1st corners
- 17-24** 1s set to 1st corner & 2nd corner ending (turning to right) between corners, all set & 1s cross RH
- 25-32** 1s+3s dance Espagnole:  
**25-26** 1s+3s cross (Ladies lead across RH passing between Men) with Ladies changing places RH  
**27-28** 1s+3s cross back (Men lead across RH between Ladies) with Men changing places RH  
**29-32** 3s turn RH as 1s turn LH to end 2 3 1

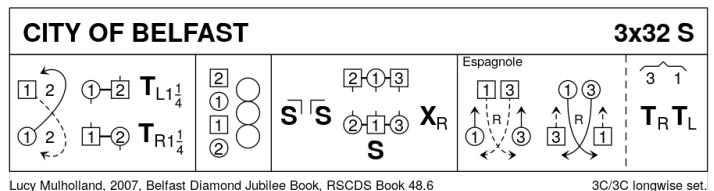

**7 THE WIND THAT SHAKES THE BARLEY R32 · 3/4L**

John M Duthie: Eight Scottish Country Dances · Crib: MiniCribs · Diagram: Keith Rose's Diagrams

- 1-8** 1s lead down for 3 steps, lead back to top of set & cast into 2nd place on own sides (2s step up)
- 9-16** 1s dance reels of 3 across, (1M with 2s & 1L with 3s), RSh to 2nd corner
- 17-24** 1s turn 1st corner, partner, 2nd corner, partner
- 25-32** All circle 6H round & back

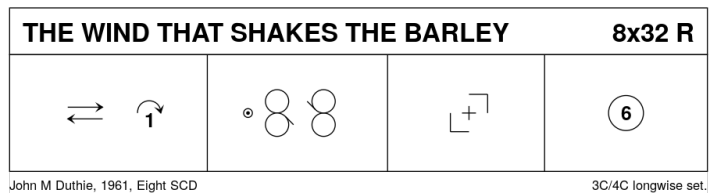

**8 FAREWELL TO BALFOUR ROAD J32 · 5/5L**

Andrew Buxton: RSCDS LII 7 · Crib: MiniCribs · Diagram: Keith Rose's Diagrams

- 1-8** 1s+2s circle 4H round & back
- 9-16** 1s+2s Set+Link; 1s+3s Set+Link
- 17-24** 2s **start while** 1s+4s+5s dance mirror reels of 3 on sides (1s in/down to start)
- 25-32** 1s set, cross down RH to 4th place (4s step up); 1s set, cross down LH to 5th place (5s step up)  
*New top couple start every 16 bars. Repeat until 1s back in 1st place, they stand for 16 bars while 5s continue bars 17-32 ending back in 5th place*

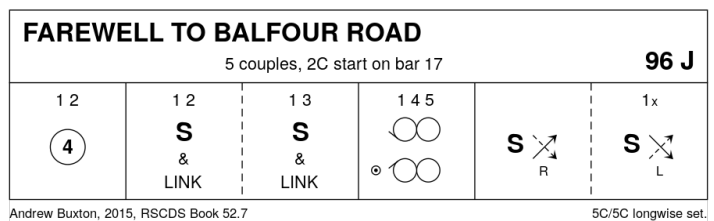

**9 A GIN AND TONIC M192 · 3/3L**

Gordon Scott: Three Hands Across · Crib: MiniCribs · Diagram: Keith Rose's Diagrams

Dance 3 times Strathspey & 3 times Reel

- 1-8** 1s+2s dance Espagnole:  
**1-2** 1s+2s cross (Ladies lead across RH passing between Men) with Ladies changing places RH  
**3-4** 1s+2s cross back (Men lead across RH between Ladies) with Men changing places RH  
**5-8** 2s turn RH as 1s turn LH to face 1st corners
- 9-16** 1s turn 1st corner, partner, 2nd corner & partner
- 17-24** 1s reels of 3 on opp sides, Lsh to 1st corners to start
- 25-32** 1s turn RH, cast, 1/2 fig of 8 through 3s

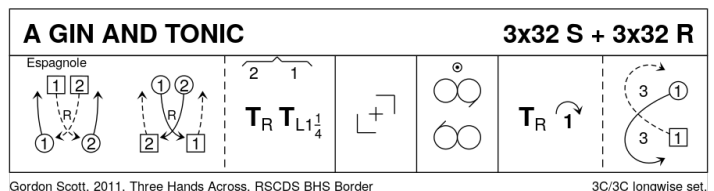

## 10 BLOOMS OF BON ACCORD R32 · 4/4L

John Drewry: Deeside Book Part 2 · Crib: MiniCribs · Diagram: Keith Rose's Diagrams

3s & 4s on opp sides

- 1-8** All set & 1s+2s also 3s+4s dance RH across once round, 1s & 4s cast in 1 place to 2 1 (4)(3)
- 9-12** 1s & 4s cross RH & cast to ends of set to meet partners in prom hold & dance into centre of dance
- 13-16** 1s+4s dance round passing RSh & to end 1s in the middle on Men's side facing up & 4s in the middle on Ladies' side facing down
- 17-24** All (1s & 4s in prom hold) dance RSh reels of 3 on sides
- 25-28** 4s+1s dance RH across in centre once round to end 4s facing up & 1s facing down
- 29-32** 4s & 1s lead out of ends crossing & cast in 1 place to end 2 4 (1) (3)

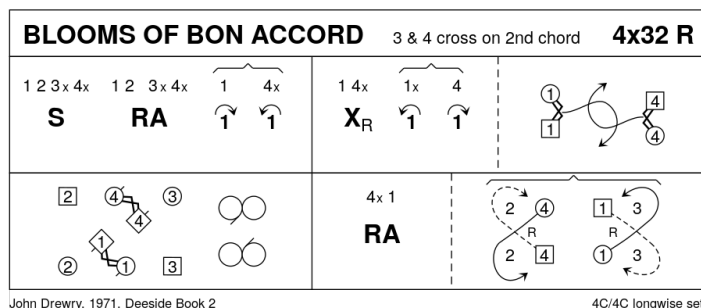

## 11 KAMO KAROUSEL J32 · 3/4L

Eddy West: The Whangarei Book of Scottish Country Dances · Crib: MiniCribs · Diagram: Keith Rose's Diagrams

- 1-8** 1s cross RH & cast 1 place, 1s dance 1/2 Figs of 8 (1L round 2s, 1M round 3s) **while** 2s+3s set & cross LH. (2)1(3)
- 9-16** 1s dance Diag R&L. 3 1 2
- 17-24** 3s+1s+2s Set & Rotate for 3 couples:  
All set & chase clockwise into lines across facing partner, all change places with partner & chase clockwise to own sides. 2 1 3
- 25-32** 2s+1s+3s circle 6H round & back

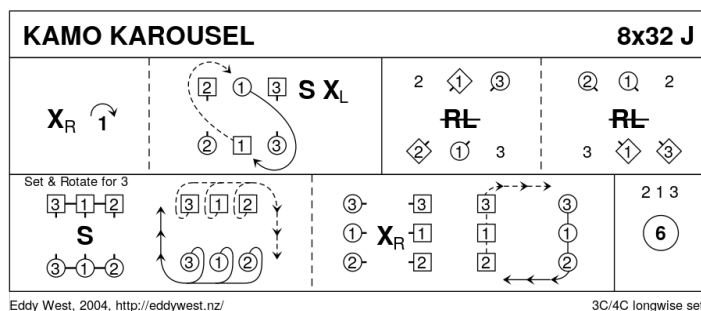

## 12 MAXWELL'S RANT R32 · 3/4L

David Rutherford: RSCDS XVIII 10 · Crib: MiniCribs · Diagram: Keith Rose's Diagrams

- 1-8** 1s cross down to dance reflection reels of 3 on opposite sides
- 9-16** 1s cross down to dance reflection reels of 3 on own sides
- 17-24** 1s cross RH, cast to 2nd place & dance 1/2 Fig of 8 round 2s
- 25-32** 1s dance down between the 3s, cast up to 2nd place & 2s+1s+3s turn partners RH

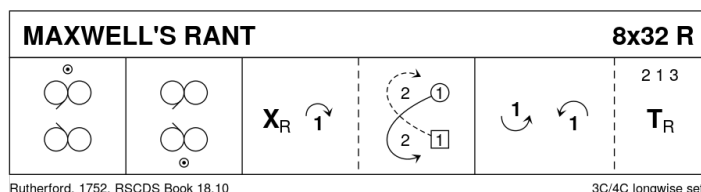

## 13 INTERVAL

## 14 PELORUS JACK J32 · 3/4L

Barry Skelton: RSCDS XLI 1 · Crib: MiniCribs · Diagram: Keith Rose's Diagrams

- 1-8** 1s cross RH & cast 1 place (2s step up 3-4), 1s dance RH across with 3s. 1s end with Man facing his 1st corner with his partner behind him
- 9-16** 1s dance Alternating Tandem 1/2 reel of 3 with 1st corners to face Man's 2nd corner, 1s dance Alternating Tandem 1/2 reel of 3 with 2nd corners
- 17-24** 1s dance Alternating Tandem 1/2 reels of 3 with Ladies' 1st corner (pstrn), 1s dance Alternating Tandem 1/2 reel with Ladies' 2nd corner (pstrn)
- 25-32** 1M followed by partner dance into LH across with 2s, 1s retain LH & 1/2 turn to own sides & 2s+1s+3s set

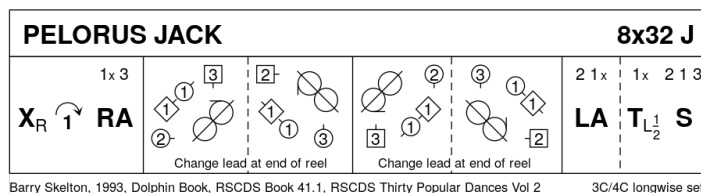

**15 THE ORCHARDS OF CO. ARMAGH S32 · 3/3L**

*Jinty Anderson: Belfast Branch Platinum Anniversary Dances · Crib: MiniCribs · Diagram: Keith Rose's Diagrams*

- 1-8** 1M leading 2M+3M also 3L leading 2L+1L chase clockwise 1/2 round to opp sides (4 bars). All set, 1s+3s turn partners 3/4 RH into line up/down (Men facing down)
- 9-12** 3s+1s dance 1/2 reel of 4, 1M+3L pass LSH to face 2s (1M+2M & 3L+2L facing), 1L+3M remain in centre at top/bottom
- 13-16** 1M+3L+2s dance 1/2 reel of 4 across, 1M & 3L pass LSh to face partners up/down set
- 17-24** 1s+3s dance 1/2 reel of 4, 1M+3L pass LSh to face own partners. 3s+1s set, petronella turn to own sides. 3 2 1
- 25-32** 2s followed by 1s dance up to top, cast, 2s to 3rd place, 1s to 2nd place (4 bars). 3s+1s+2s turn partners 2H

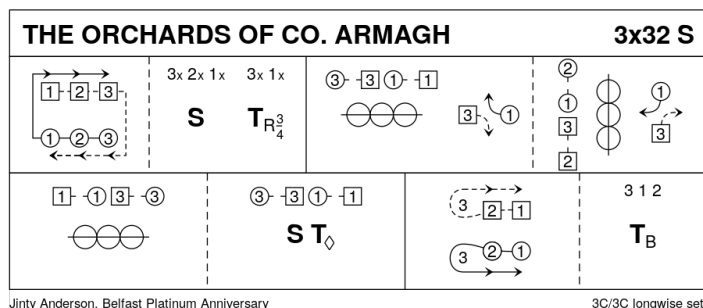

**16 STAIRCASE IN STYRIA R40 · 5/5L**

*Margaret Gray: CD booklet of The Sunday Class Dance Book 2 · Crib: MiniCribs · Diagram: Keith Rose's Diagrams*

- 1-8** 1s+2M also 3s+4M dance RH across, 1s+2L also 3s+4L dance LH across
- 9-16** 1s+4M also 3s+5M dance RH across, 1s+4L also 3s+5L dance LH across & 1L also 3L end facing out Ladies side with partners behind them
- 17-24** 1s & 3s dance out Ladies' side & cast up 1 place, cross to Mens side & cast up to original place Ladies looping round by the right
- 25-32** 1s cross & cast 1 place, 1s followed by 3s dance up & cast (1s to 3rd place, 3s to 2nd place)
- 33-40** 1s cross & cast 1 place, 1s followed by 5s dance up & cast (1s to 5th place, 5s to 4th place). 2 3 4 5 1  
NB - No stepping up or down until bar 27

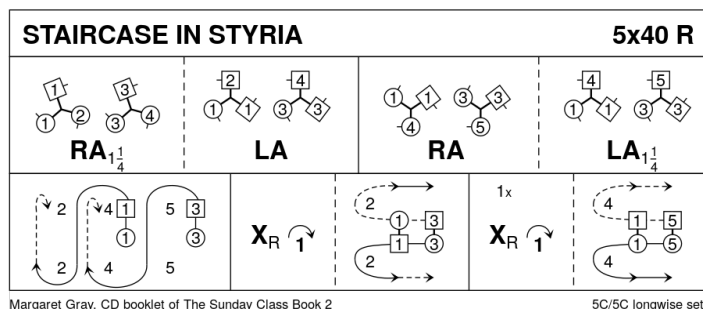

**17 BILL CLEMENT MBE J32 · 3/4L**

*John Wilkinson: RSCDS XLVII 1 · Crib: MiniCribs · Diagram: Keith Rose's Diagrams*

- 1-8** 1s set & dance down between 3s & cast up to end LH with partner facing 1st cnrns
- 9-16** 1s set & turn inwards to face 3rd cnrns, 1s set to 3rd cnrns & turn cnrns LH to end RH with partner facing 2nd cnrns
- 17-24** 1s set & turn inwards to face 4th cnrns, 1s set to 4th cnrns & turn cnrns RH to end 2nd place own side
- 25-32** 2s+1s+3s circle 6H round & back

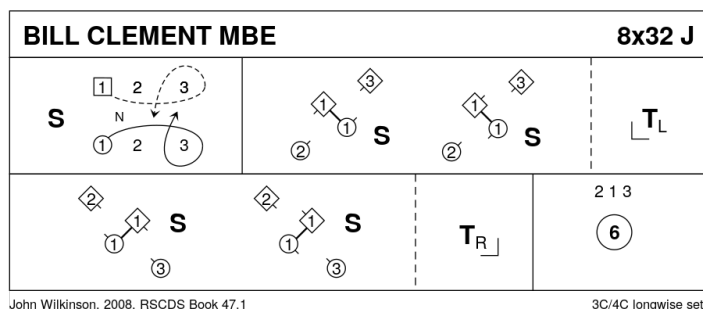

**18 ASILOMAR ROMANTIC S32 · 3/4L**

*Tom Cuthbertson: Thirty Popular Dances, Volume Two · Crib: MiniCribs · Diagram: Keith Rose's Diagrams*

- 1-8** 1s+3s dance double Fig of 8 around 2s, 1s crossing down, 3s cast up to start
- 9-16** 1s+2s dance Pousette
- 17-24** 1s dance in & down between 2s (2s step up), set to each other & dance RSh round 4th corner to face own 1st corner
- 25-32** 1s dance 'Hello-Goodbye' setting ending with petronella turn to 2nd places. 2 1 3

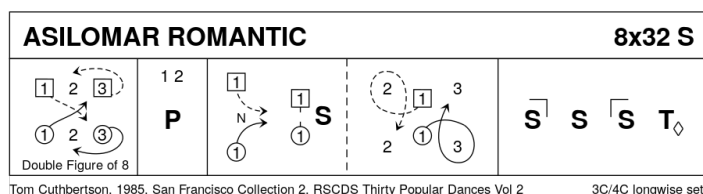

Note: End of 2nd turn it may help if 1s step in & down to 4th place as 3s cast up into double Fig 8

## 19 THE ELUSIVE MUSE J32 · 3/3L

Tim Wilson: Measures of Pleasure · Crib: MiniCribs · Diagram: Keith Rose's Diagrams

- 1-8 1L dances RSh round prtnr to face 2L, 1s (1L leads) dance 1/2 Tandem reel of 3 across with 2s (LSh to 2L) ending 2s to top & 1s facing down
- 9-16 1s dance down (4 bars), Lady turns under Mans arm & dance up to face 3L
- 17-24 1s (1L leads) dance 1/2 Tandem reel of 3 across with 3s (RSh to 3L), 1s dance up to top & cast to 2nd place opposite sides
- 25-32 2s+1s+3s Set+Link for 3 twice to end 3 1 2

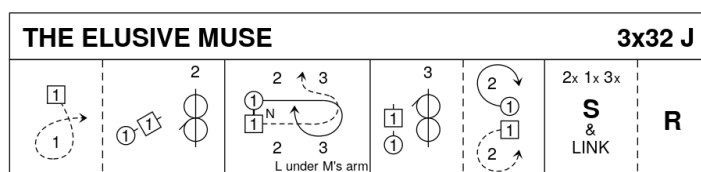

Tim Wilson, 2003, Measures of Pleasure, www.rscds-sf.org/resources/dances

3C/3C longwise set.

## 20 THE CASTLE OF MEY R32 · 3/4L

John Walton: QE Diamond Jubilee Dances · Crib: MiniCribs · Diagram: Keith Rose's Diagrams

- 1-8 1s dance Inveran reels with 2s+3s
- 9-16 1s+2s dance double Figs of 8 (1s start by crossing down)
- 17-24 1s lead down the middle & up, 1s end in middle of the set
- 25-32 1s+2s dance Poussette

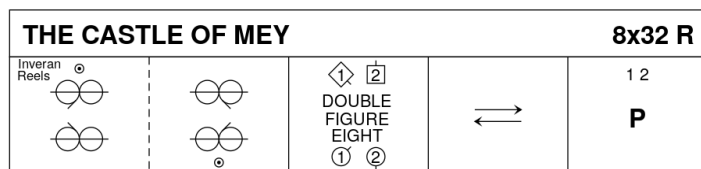

John Walton, 2012, RSCDS QE Diamond Jubilee

3C/4C longwise set.

## 21 THE LAST SET IN THE HALL S32 · 3/3L

Truus de Ceuster: Eight by Thirty-Two · Crib: E-cribs · Diagram: Keith Rose's Diagrams

- 1-- 1c+2c Knot, 1c finish facing 1cnrs
- 9-- 1c set to 1cnr | 1c cast Rsh round each other to 3cnr position while 1cnrs dance into centre, and swivel R to face own cnr ; repeat, 1cnrs finishing in exchanged places, and 1c twirl to face 2cnr
- 17-- Repeat with 2cnrs (3x,1x,2x)
- 25-- All set | All turn P BH 1½ and face P | twirl R to own side (3,1,2)

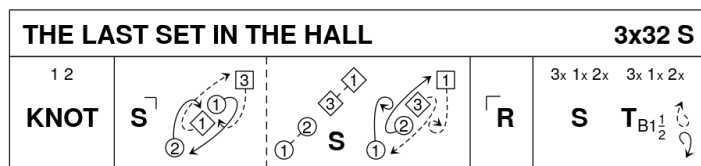

Truus de Ceuster, 2014, blog.lib.umn.edu/dfs/8x32

3C/3C longwise set.

## 22 SLEEPWALKING R32 · 3/4L

Katherine Giacoletti · Crib: MiniCribs · Diagram: Keith Rose's Diagrams

- 1-8 1s cross RH, cast to 2nd place (2s step up), turn LH & cast down to 3rd place (3s step up)
- 9-16 1s dance reflection reels on opposite sides (1s in/up, 3s out/down, 2s in/down to start)
- 17-24 1s dance up to top, cast to 2nd place while 3s continue reel to 3rd place; 1s dance 1/2 Fig of 8 round 3s
- 25-32 1s turn 1st corner RH, pass RSh, turn 2nd corner RH & pass RSh to 2nd place own sides (corners turn for 4 bars)

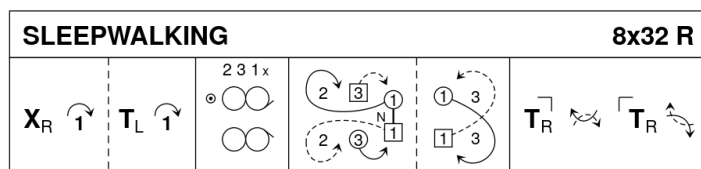

Katherine Giacoletti, 1996, Delaware Valley Gold

3C/4C longwise set.

## 23 ST BERNARD'S WALTZ W16 · 1RR

Bill Smith: A Guide to Scottish Country Dancing (ex-Collins) · Crib: MiniCribs · Diagram: Keith Rose's Diagrams

Couples in ballroom hold face anticlockwise round room, Ladies on the outside

- 1-8 All in waltz hold take 3 steps (Lady right, Man Left) & stamp both feet, 2 steps in opposite direction then 2 steps towards centre (start Lady right foot, Man left foot)
- 9-16 All take 2 steps back out & Lady turns under Man's right arm, all waltz round room

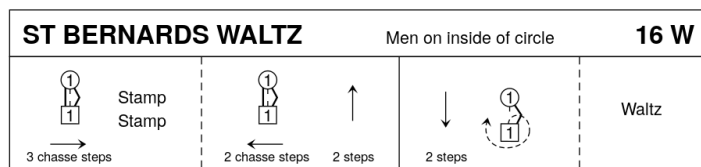

Bill Smith, 1913, Guide to SCD

1C/1C Round the Room.

**24 THE BEES OF MAGGIEKNOCKATER**

J32 · 4/4L

John Drewry: *Thirty Popular Dances, Volume Two · Crib: MiniCribs · Diagram: Keith Rose's Diagrams*

- 1-8** 1s cross RH & cast 1 place, dance RH across with 3s & end 1M+3L also 1L+3M in prom hold facing out to pass corner person RSh
- 9-24** All dance 4x1/2 Reels of 3 on sides (to right to start, then left, right & left) with 1s+3s changing partners in centre at end of each 1/2 Reel to progress Men clockwise & Ladies anticlockwise. End in centre 1s facing down & 3s facing up
- 25-32** 1s dance between 3s turning 3s with nearer hand 1.1/2 times, crossing over to own sides & turn 4th person 1.1/2 times (Men RH & Ladies LH)

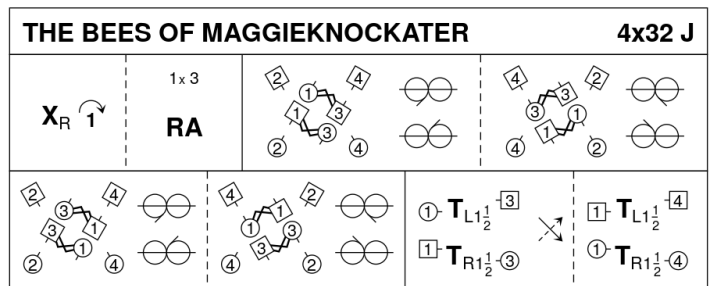

John Drewry, 1975, Canadian Book, RSCDS Thirty Popular Dances Vol 2

4C/4C longwise set.

**25 DA RAIN DANCIN'**

R32 · 3/4L

Ron Wallace: *Thirty Popular Dances, Volume Two · Crib: MiniCribs · Diagram: Keith Rose's Diagrams*

- 1-8** 1s dance down below 3s, cast up round 3s to 2nd place own side, 2s+1s+3s set & cross RH
- 9-16** 1s dance up round 2s & cast down to 2nd place opposite sides, 2s+1s+3s set, 1s turn LH to face 1st corners **while** 2s & 3s cross LH
- 17-24** 1s set to corner (1), set to partner (1) & turn 3/4 RH (2 bars) to face 2nd corner; 1s set to corner (1), set to partner (1) & turn 3/4 RH (2 bars) to 2nd place own side
- 25-32** 2s+1s+3s circle 6H round & back

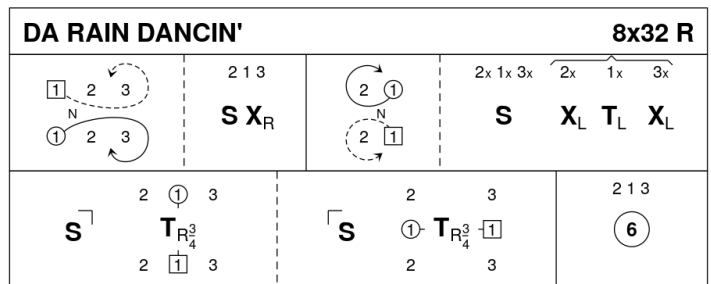

Ron Wallace, 1991, Whiteadder Collection, RSCDS Thirty Popular Dances Vol 2

3C/4C longwise set.